



Capacitor (*i-ELOOP*)

Disposal Manual

Mazda ***CX-5***

(Vehicle type in VIN : JM* KF ***** 100001 ~
PP1 KF *****M *10001 ~
RUM KE *W***** 100001 ~)

May 2017

Mazda Motor Corporation

Contents

I . Introduction

II . Recommendation for safe disposal of capacitor

III . Precautions if visible leakage occurs from the capacitor

IV . Compulsory discharge procedure of the capacitor (*i - ELOOP*)

Appendix

I . Introduction

Part of vehicles Mazda Motor Corporation produces are equipped with the capacitor for the regenerative braking system (i-ELOOP).

Please make sure to discharge the capacitor compulsorily first time after accepting an end of life vehicle according to this manual when the vehicle with the capacitor is dismantled.



Warning

- If the vehicle or parts are disposed of (scrapped) while the capacitor (i-ELOOP) is charged with electricity, it could cause the following accidents. Before disposing of the vehicle or parts, always discharge the capacitor (i-ELOOP) to prevent the following accidents from occurring.
 - Ignition generated by a shorted current may ignite flammable objects
 - The wiring harness temperature increases by the shorted current while it is disconnected and cause severe burns and serious injury if the wiring harness is touched
 - Touching the wiring harness while your body is wet with the wiring harness disconnected may result in electrical shock

- If the terminal of one of the i-ELOOP-related parts contacts the vehicle body with the service plug of the capacitor connected, it could cause a fire and damage to electrical parts. In addition, if the terminal contacts your body, it could cause electrocution. Disconnect the service plug of the capacitor before disconnecting the i-ELOOP-related part terminal.
 - Battery cable terminal of capacitor (i-ELOOP)
 - Engine wiring harness terminal of capacitor (i-ELOOP)
 - Battery cable terminal of DC-DC converter (i-ELOOP)
 - Generator terminal B cable

II . Recommendation for safe disposal of capacitor

- 1. Deformation, cracks, power leakage, an electrolyte leakage may occur with the capacitor if the vehicle is involved in an accident. This could result in fire, smoke, and electrocution due to a short circuit.**
 - When performing a compulsory discharge on such a vehicle, or if the capacitor cannot be compulsory discharged due to an accident, consult an Authorized Mazda Dealer.
- 2. Disconnect the negative battery cable before performing a compulsory discharge of the capacitor**
 - Performing the discharge procedure without disconnecting the negative battery cable may cause fire and smoke.
- 3. Always remove the service plug before performing a compulsory discharge of the capacitor**
 - If the terminal of one of the i-ELOOP-related parts contacts the vehicle body while the service plug of the capacitor is installed, it could cause a fire and damage to electrical parts.
- 4. The electrolyte capsulated inside capacitor is an organic solvent containing an organic boron compound. The capacitor contains 1000 ml of the solvent.**
 - If visible leakage from the capacitor occurs, refer to "Precautions if visible leakage occurs from the capacitor"
- 5. After discharging the capacitor, do not throw it into a fire or allow it to come close to heat, or become heated.**
- 6. If the capacitor itself is to be disposed of**
 - Dispose of the capacitor in accordance with your local laws and regulations. Please refer to the appendix for your information. Usually removing a capacitor from a vehicle is not necessary when the vehicle is disposed of.
- 7. Do not neglect, divert, modify, or disassemble the capacitor**
 - Accidents and injury could occur as a result of touching an improperly disposed of capacitor. Fire, smoke, and electrolyte leakage may occur if a capacitor is disassembled or modified, or it is diverted or reused on vehicles other than the i-ELOOP equipped vehicle, or used for other purposes.

Mazda Motor Corporation assumes no responsibility whatsoever for any accidents or loss caused by re-appropriation, modification, or disassembly of a used capacitor, or any accident or loss caused by neglect, resale, or transfer of the capacitor. Business operators conducting such activities hold responsibility.

8. If fire occurs near a capacitor

- Use dry chemicals for a small fire.
- Use alcohol-resistant foam, water spray, or mist for large fires.
- Stay upwind and extinguish the fire wearing a respirator for protection from smoke and combustion by-product inhalation.

III. Precautions if visible leakage occurs from the capacitor

- Avoid inhalation of the material, and avoid contact with eyes, skin, and clothing.
- Wash hands and face sufficiently after handling.
- Keep the capacitor away from flames or sources of heat.
- Wear protective gear such as rubber gloves, protective goggles, and a gas mask.
- Dilute the liquid with water and wipe it off
Properly dispose of the waste cloth used for wiping the liquid as industrial waste.
- Skin contact
Wash the skin immediately with plenty of water or hot, soapy water for at least 15 minutes.
Obtain medical attention if skin irritation occurs.
Remove contaminated clothing immediately.
- Eye contact
Immediately wash eyes with plenty of water for at least 15 minutes and obtain medical attention.
- Inhalation
Immediately move anyone exposed to contamination to an area with fresh air.
Keep the victim warm and quiet and obtain medical attention.
- Ingestion
Have the person drink a glass of water or milk.
Obtain medical attention immediately.

IV. Compulsory discharge procedure of the capacitor (*i-ELOOP*)

■ Location of the capacitor

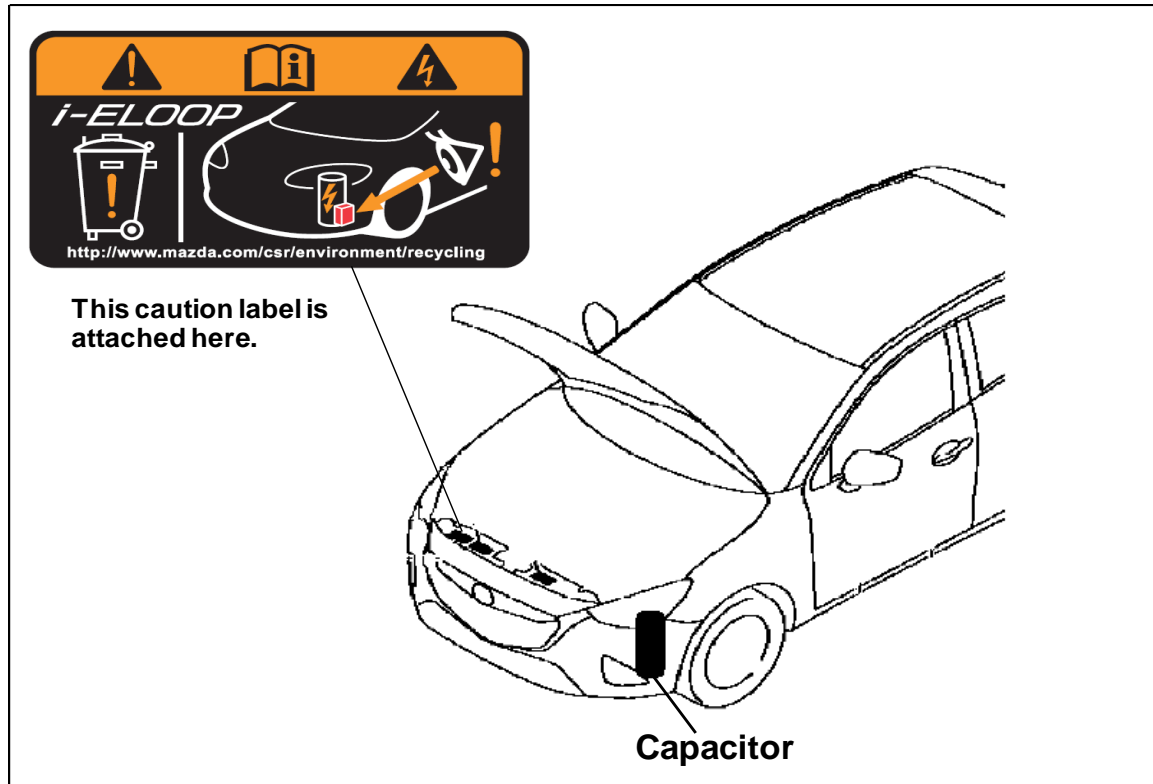

■ Capacitor (i-ELOOP) compulsory discharge

1. Turn the steering wheel completely to the right.
2. Switch the ignition off.
3. Disconnect the negative battery terminal.
 - When disconnecting the plastic deformed negative battery terminal, expand the gap of the negative battery terminal using a flathead screwdriver, and remove the nut.

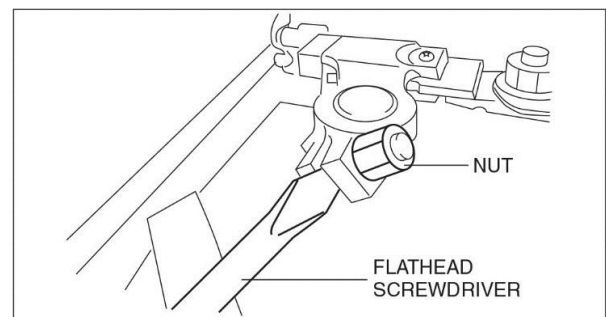

4. Remove the fasteners.

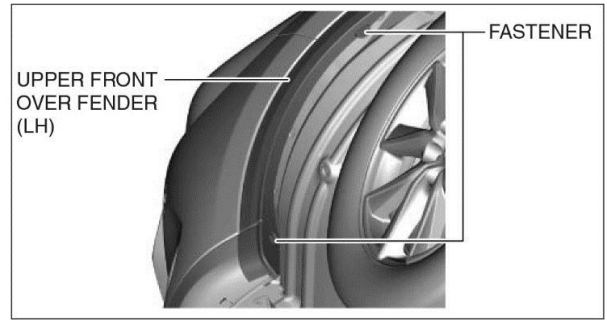

5. Pull the upper front over fender (LH) in the direction of the arrow shown in the figure and detach the clips starting from the vehicle front.

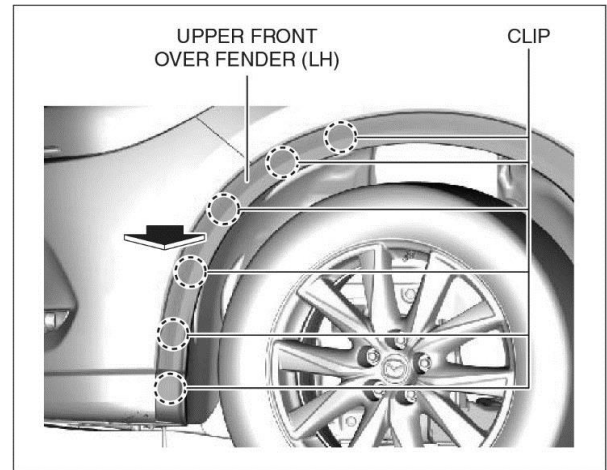

6. Remove the fasteners.

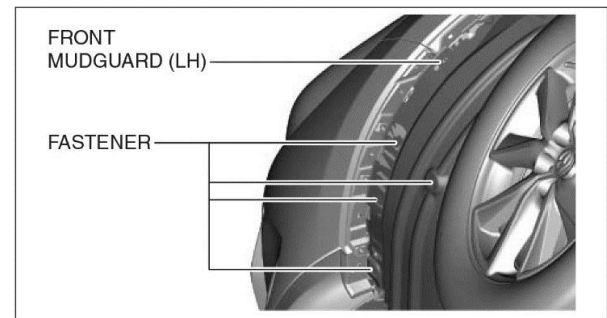

7. Remove the service plug installation bolt shown in the figure.

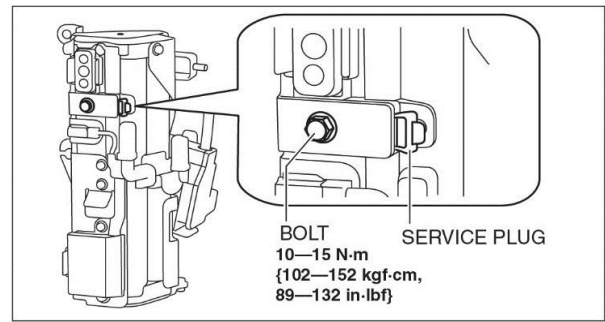

8. Pull the service plug in the direction of the arrow shown in the figure.

Note

- The service plug cannot be completely removed.

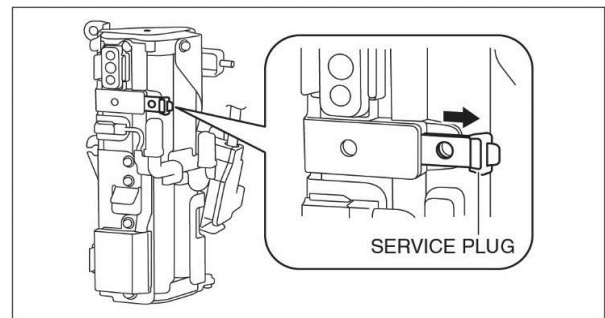

9. Using the removed installation bolt, temporarily hold the service plug at the position to which it was pulled.

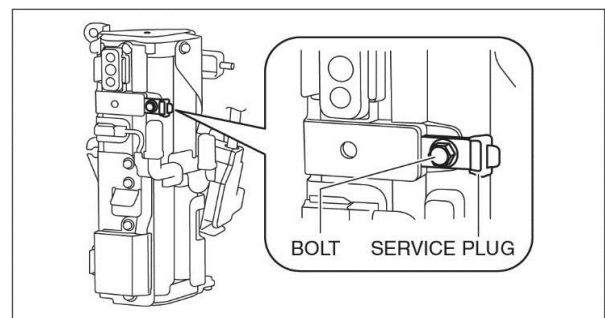

10. Remove the discharge box cover.

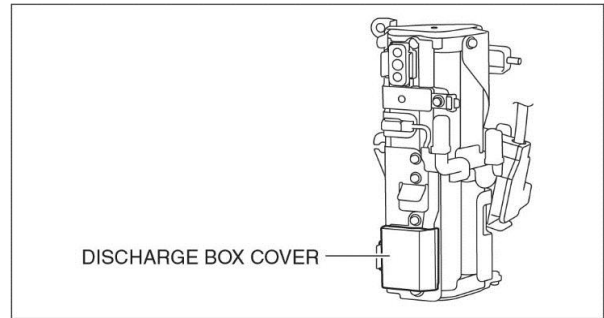

11. Connect the connector in the discharge box to the plug.

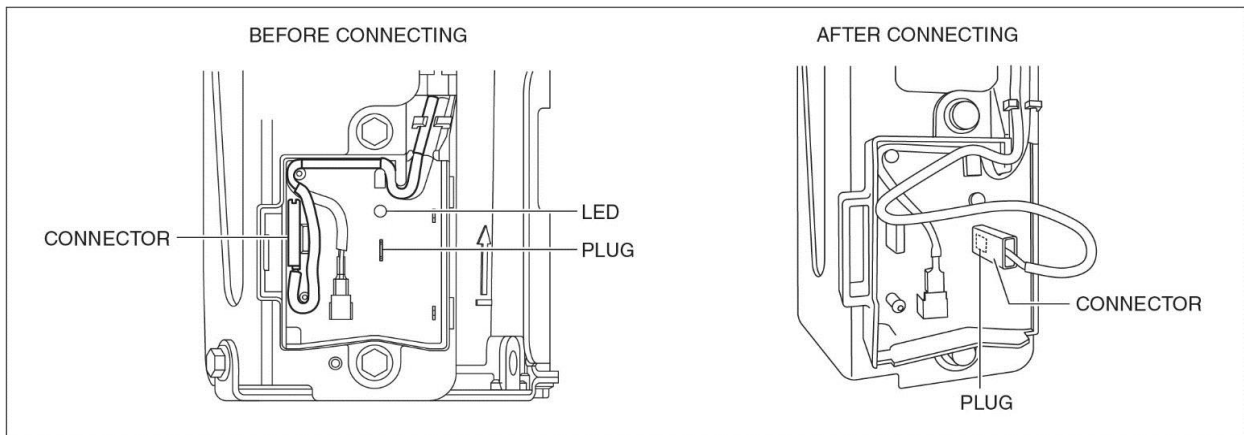

12. Verify that the LED which displays during discharging is displayed.

Caution

- Do not touch the discharge box because the inside of the box becomes hot during discharging.

Note

- The LED turns off when the discharge is completed. Completion of discharge takes a maximum of approx. 2 hours.

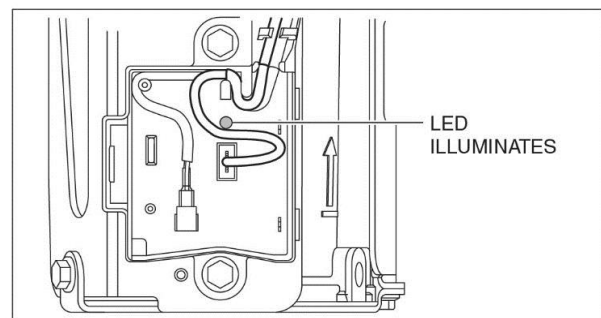

13. Verify that the LED turns off.

Caution

- Do not return the service plug to the original position even after discharging is finished.

14. Dispose of the vehicle or the parts in accordance with your local laws and regulations.

Appendix

PRODUCT SPECIFICATION

1. IDENTIFICATION

CAPACITOR

2. COMPOSITION INFORMATION

HAZARDOUS INGREDIENTS		%	CAS NUMBER
Exterior	Iron	28% or less	NA
Electrode	Aluminium	17% or less	NA
Electrolyte	Organic electrolyte solution primarily containing carbonate ester	17% or less	NA
Exterior	Synthetic Resin (PP,PBT)	6% or less	NA

3. HAZARDS IDENTIFICATION

NFPA/HMIS RATING (0=minimal, 1=slight, 2=moderate, 3=serious, 4=severe)

Iron	Health=0, Fire=0, Reactivity=0
Aluminium	Health=0, Fire=0, Reactivity=0
Organic electrolyte solution primarily containing carbonate ester	Health=1, Fire=1, Reactivity=0
Synthetic Resin (PP,PBT)	Health=1, Fire=1, Reactivity=0

GENERAL SAFETY CONSIDERATIONS

- Cells inside the product may vent/rupture if overcharged, reverse charged, incinerated or heated to abnormally high temperature.
- Do not crush, mutilate, nail penetrate or disassemble the product.
- High case temperature may result from charge-discharge of the product.

4. FIRST AID MEASURES

If the outer casing of the cell is damaged, and exposure to internal electrolyte within the product occurs, the following actions are recommended.

INHALATION

Move to the area with fresh air, then keep rest at quiet and warm condition. Seek medical attention.

EYE CONTACT

Immediately flush the eyes sufficiently with water for 15 minutes, and have immediate medical treatment.

SKIN CONTACT

Immediately wash it down with a large quantity of water, and thoroughly wash the skin with soap. If there is a fear of burn, have immediate medical treatment.

INGESTION

Drink milk/water and induce vomiting; seek medical attention.

5. FIRE FIGHTING MEASURES

FIRE AND EXPLOSION HAZARDS.

High temperature can generate flammable vapor. When mixed with air and exposed to ignition source, vapors can burn in open or explode if confined. Vapors may be heavier than air.

EXTINGUISHING MEDIA

Dry chemical, carbon dioxide, dry sand

FIRE FIGHTING

Move the product from fire area if it can be done without risk.

Avoid inhalation of material or combustion by-products. Stay up wind and keep out of low areas. Wear adequate personal protective equipment.

6. ACCIDENTAL RELEASE MEASURES

NA

7. HANDLING AND STORAGE

HANDLING

Avoid exposing to fire. Do not short-circuit the terminal with it charged.

Do not install or disinstall the product while it is charged.

Wear protect equipment such as protect glasses or gloves.

STORAGE

Store the product under the environment which is free from high temperature, high humidity, rain, dew, or sunlight.

Store the product under the environment without a risk of toxic gas, droplet, dust generation/invasion or submergence.

Store the product under the environment which is free from fire.

Avoid rapid temperature change as it leads to dew condensation or degradation of the product.

Store the product upward to prevent liquid leakage.

Store the product with it terminals short-circuited after discharge.

8. EXPOSURE CONTROLS/PERSONAL PROTECTION

EXPOSURE CONTROL

Keep the regulations for export since electrolyte may leak in case the product is turned, fallen or given a strong impact.

Please connect it to specified devices only.

PERSONAL PROTECTION

(Respirator)	Not required during normal operations.
(Eye/face protection)	Not required beyond safety practices of employer.
(Gloves)	Gloves recommended to handle the product.
(Foot protection)	Steel-toed shoes recommended.

9. PHYSICAL AND CHEMICAL PROPERTIES

State:	Solid
Odor:	NA
pH:	NA
Vapor pressure:	NA
Vapor density:	NA
Boiling point:	NA
Solubility in water:	
Except electrolyte insoluble	
Electrolyte soluble	

10. STABILITY AND REACTIVITY

REACTIVITY

None

INCOMPATIBILITIES

None during normal operation. Avoid exposure to heat, open flame and corrosive.

HAZARDOUS DECOMPOSITION PRODUCTS

None during normal conditions.

CONDITIONS TO AVOID

Avoid exposure to heat and open flame.

11. TOXICOLOGICAL INFORMATION

This product is not toxic during routine handling and use.

Sensitization:	NO
Teratogenicity:	NO
Reproductive Toxicity:	NO
Acute Toxicity:	NO

12. ECOLOGICAL INFORMATION

Under normal conditions, the product poses no risk to persons or the surrounding environment.

13. DISPOSAL CONSIDERATIONS

Discharge the electricity to safety voltage before disposal.
The product shall be treated in accordance with relative national law and regulations.

14. TRANSPORT INFORMATION

Handle with care so that no electrolyte leak occurs by overturning or dropping the product.
Be careful not to drop as it is a heavy device.
Fumigation process may be required for export in some countries.
Some types of fumigation process which uses halogenated ions may cause corrosion.

15. APPLICABLE LAWS AND REGULATIONS

HAZARDOUS MATERIALS STORAGE AND AIR TRANSPORTATION REGULATIONS

UN Number NA

It can be shipped as regular cargo as it complies IATA Dangerous Goods Regulation, Special Provision A186.

HAZARDOUS MATERIALS STORAGE AND SHIP TRANSPORTATION REGULATIONS

UN Number NA

It can be shipped as regular cargo as it complies Special Provision 361.

16. OTHER INFORMATION

NA: Not Applicable